

REJUVENATING OUR AGING STRUCTURES: CUMBERLAND STREET PARKING GARAGE REHABILITATION

BY PHILIP SARVINIS

The Cumberland Street Parking Garage is located in the heart of downtown Toronto's High Fashion District, an area where vehicle parking is at a premium. The parking structure, which was built in 1968, is typically above ground and consists of five parking levels, four of which are suspended parking levels. Three and one-half of the parking levels are above ground and one and one-half are below ground. The structure has a rectangular footprint with approximate plan dimensions of 260 ft (79.3 m) in the north/south direction and 100 ft (30.5 m) in the east/west direction. The garage has the capacity to hold around 300 vehicles with approximately 120,000 ft² (11,150 m²) of parking, of which 24,000 ft² (2,230 m²) is on grade and 96,000 ft² (8920 m²) is suspended slab.

The parking structure is bound on the east and west sites by adjacent buildings with minimal separation between the structures. Retail space occupies a portion of the north and south elevation of the structure, and a retail car rental company and an auto carwash and detailing company occupy a portion of the basement level of the garage.



Fig. 1

The functional layout of the garage provided two-way traffic flow to all levels of the split-level garage, which act in a helical fashion, and has parking stalls perpendicular to the flow of traffic. Entrance and exit for the facility can be gained via both Yorkville Avenue to the north and Cumberland Street to the south.

STRUCTURAL CHARACTERISTICS

The suspended slabs of this parking garage are typically 8 in. (203 mm) thick cast-in-place post-tensioned concrete one-way spanning slabs. The slabs are supported by 30 in. (762 mm) deep by 18 in. (457 mm) wide post-tensioned concrete beams spaced at 28 ft (8.5m) centers, and are also typically one-way spanning. The post-tensioning system within the suspended slabs is an unbonded post-tensioning system known as a button-head system. The post-tensioning system in the beams is also the button-head system; it is, however, of the bonded type (that is, placed in solid grout-filled ducts). The suspended slabs have a nominal amount of mild reinforcing steel embedded within (that is, No. 3 bars at 16 in. [406 mm] centers each way) to control cracking due to temperature fluctuations (refer to Fig. 2).

The columns, foundation walls, and stairwell cores are all of normally reinforced cast-in-place concrete construction. The foundations are a combination of reinforced concrete strip and pad footings.

As noted previously, the parking slab arrangement is one of a split-level design dividing the structure in half in the east/west direction. There is also one expansion joint that travels in the east/west direction dividing the structure once again into two halves in the north/south direction. These division points define the various quadrants of the garage.

MOISTURE PROTECTION SYSTEMS

Up until 1998, the suspended slabs of this facility were not waterproofed to protect against the ingress of moisture and harmful chlorides. At the time of construction, a surface sealer was applied to the top

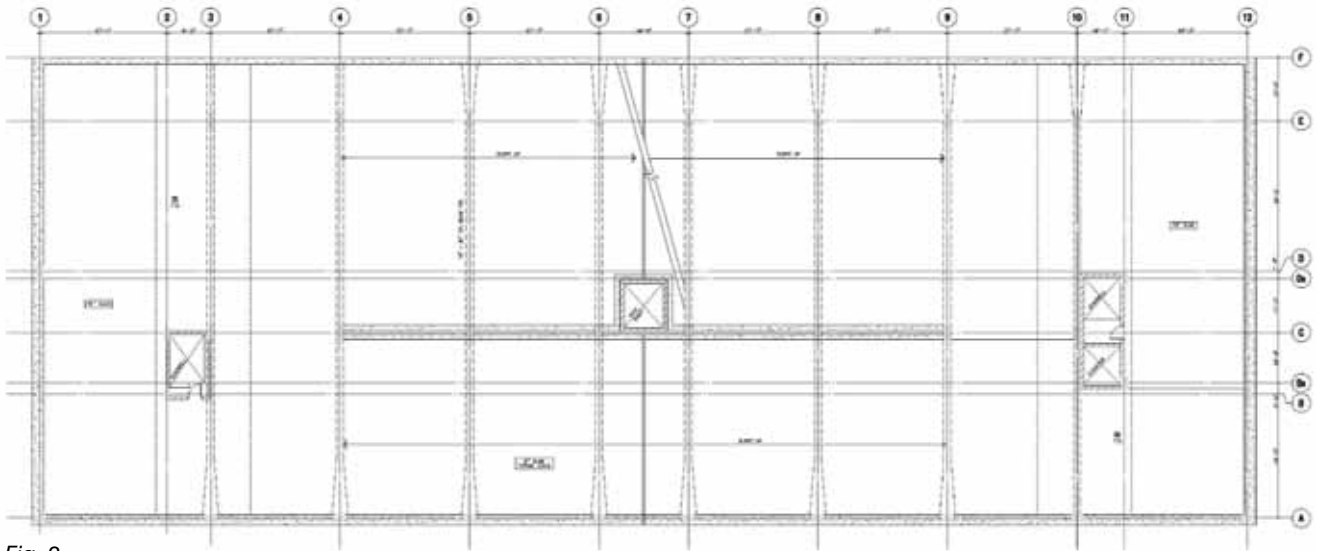

Fig. 2

surface of the suspended parking slabs. In 1998, a staged installation of waterproofing (thin traffic deck coating) began, and today, only the exposed roof level remains to be protected with a waterproofing system.

BUTTON-HEAD POST-TENSIONING SYSTEM

POST-TENSIONING BASICS

Post-tensioning is a method of introducing internal forces into a concrete element after the element has been cast to counteract the external loads that will be applied to the element when it is put into use. When the element is post-tensioned, the concrete portion of the element is put into compression and the steel portion of the element is put into tension. Putting the components of the element into this state prior to applying a service load forces the building materials in a stronger state, resulting in a stiffer element that now has more capacity to resist tensile forces.

The first successful use of unbonded post-tensioning systems dates back to 1920 to 1930 in Europe, and it was not until the 1960s that it became popular in North America.

BUTTON-HEAD SYSTEM

The term “button-head” refers to the shape of the wire’s end after it is anchored. The button-head system installed in this facility’s parking slabs consists of 0.25 in. (6.35 mm) diameter high-strength steel (240,000 psi [1655 MPa]), cold drawn, stress-relieved wires which are bundled together into tendons and wrapped with protective greased paper. Tendon sizes ranged from 7 wires to 19 wires in each bundle and were typically spaced at 4 ft (1.2 m) centers. The button-head system is an early type of post-tensioning technology and possesses very little protection against moisture and



Fig. 3

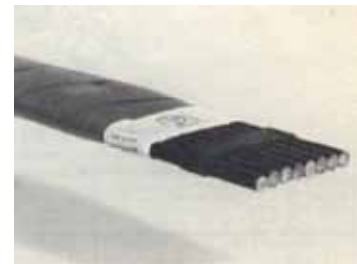

Fig. 4 and 5

chloride attack. The post-tensioning system in the suspended slabs of this parking garage is an unbonded system, meaning it is anchored to the concrete slab at the end anchor locations only. The post-tensioning in the concrete beams is a grouted or bonded system and, thus, not as susceptible to moisture deterioration as the unbonded slab system.

All wires of the post-tensioning strand were cut to the same length and then passed through predrilled holes in the anchor head. To secure and seat the wires against the anchor head, a small button-like configuration was cold-formed onto the end of each wire. The dead end side of the strands was cast into the structure at the time of concrete placement. At the live end, the tendon wire first

passed through a bearing end plate before it was threaded through the live end anchor head and seated with button-heads. During the concrete placement, the bearing end plate was also cast into the concrete, leaving the ends of the wires and anchor head at the live end exposed for stressing. After stressing, the wires elongate, creating a gap between the anchor head plate and the embedded bearing plate. To maintain this tension force and transfer it into the bearing plate, transfer plates were installed in the gap between the anchor and bearing plates. The live anchor was then cast in concrete.

Unfortunately, the cross section of the tendon was typically found to be irregularly shaped primarily due to the manual paper-wrapping operation. This cross section makes removal of the button-head tendon impossible as compared to present day post-tensioning systems.

Because the unbonded button-head post-tensioning system is susceptible to moisture and chloride attack, it was found that as the structure continued to age and experience this ongoing moisture and chloride ingress, the embedded post-tensioning strands were deteriorating and becoming distressed, resulting in a reduced load-carrying capacity of the suspended parking decks.

PAST EVALUATIONS

Read Jones Christoffersen's involvement with this structure dates back to 1985. Since 1985, the



Fig. 6



Fig. 7

structure, and in particular the post-tensioning system, was evaluated over the years to identify signs of corrosion-related deterioration, tension deficiencies in the post-tensioning, and reductions in load-carrying capacity.

The parking slab evaluation included traditional condition survey techniques such as visual reviews, acoustical sounding (chain drag, hammer tap surveys), chloride-ion content testing, comprehensive strength surveys, deflection surveys, and load tests. The review of the post-tensioning expanded the traditional survey to include the introduction of inspection recesses in the slabs to exposed short sections of the embedded post-tensioning system. The inspection recesses allowed the condition of the paper wrapping and protective grease to be reviewed and analyzed, allowed the exposed section of wires to be reviewed for corrosion, and allowed testing for tension deficiencies in the post-tensioning system.

Over the years, as deterioration was detected with respect to embedded mild reinforcing steel, repair programs were implemented to locally repair any concrete deterioration as well as protect the suspended slabs with a traffic-bearing waterproofing system. These programs also included the replacement of expansion joint seals.

With respect to the post-tensioning system, however, it was analyzed on a quadrant-by-quadrant basis. Once it was found to have lost load-carrying capacity to a point that was deemed to be below the design loads it currently supports, external reinforcing was installed. Being unable to physically remove and replace the defective button-head post-tensioning system, an external post-tensioning system was designed and installed through the existing structural slabs to replace the original system. The external post-tensioning was done on a quadrant-by-quadrant basis.

The deterioration of the post-tensioning system to date has been limited to the unbonded post-tensioning system within the slabs. The bonded post-tensioning system in the beams appears to be functioning well.

EXTERNAL POST-TENSIONING REHABILITATION SOLUTION

GENERAL SYSTEM DESCRIPTION

Once a quadrant was deemed to be in need of external reinforcement, calculations were performed based on the extent of mild reinforcing and transverse post-tensioning to determine the maximum spacing between the proposed external post-tensioning system (that is, 8 ft [2.4 m] centers) (refer to Fig. 7). The new external post-tensioning consists of 7-wire high strength (270,000 psi [1860 MPa]) low relaxation steel strands in extruded plastic sheathing. The sheathing was high-density

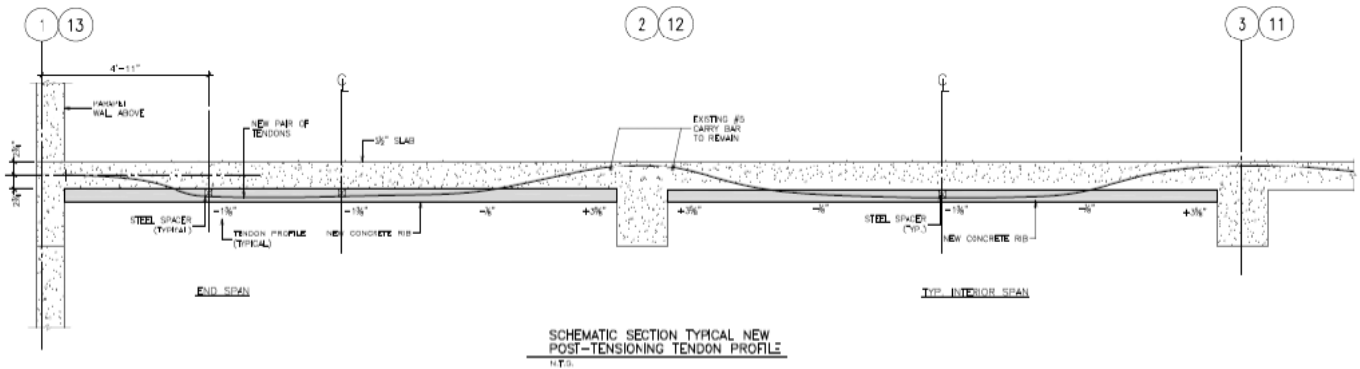

Fig. 8

polyethylene with a minimum wall thickness of 0.06 in. (1.5 mm). The tendons were placed at 8 ft (2.4 m) centers, and at each location there were three tendons that ran the full length of the quadrant. At end bays, each line of external post-tensioning had an extra two tendons (five total) to accommodate the extra span and flexural moment due to the end conditions.

At each external post-tensioning location, the tendon groups were threaded through the existing suspended slab and anchored at each end. The dead ends were typically located at the expansion joint, whereas the live ends (stressing end) were at the building exterior elevation to accommodate the stressing. The tendons had a draped profile with high points at beam support lines and low points at mid-bay between beams (refer to Fig. 8).

At high points, troughs were chipped in the slab surface to allow the new tendons to obtain the appropriate concrete cover (refer to Fig. 9 and 10). To achieve the appropriate drape, trough slab openings were chipped in the suspended slabs to allow the tendons to be threaded down to the underside of the slab and back up at the next beam line (refer to Fig. 11).

The exposed portion of the tendons below the existing slab were then encapsulated in reinforced concrete beams or ribs to provide the required slab-strand integration and overall fire protection to the system (refer to Fig. 12 and 13).

During the process, the existing post-tensioning system remained in place and was destressed simultaneously with the stressing of the new external system to ensure the existing suspended slabs were not overstressed at any time during construction. The new tendons were stressed to a final effective stress of 173 ksi (1193 MPa).

ADVANTAGES OF SOLUTION

The primary advantages of the external post-tensioning solution were as follows:

1. Allowed the majority of the existing suspended slabs to be reused;
2. Permitted the work to be undertaken in phase, which allowed traffic flow to continue through

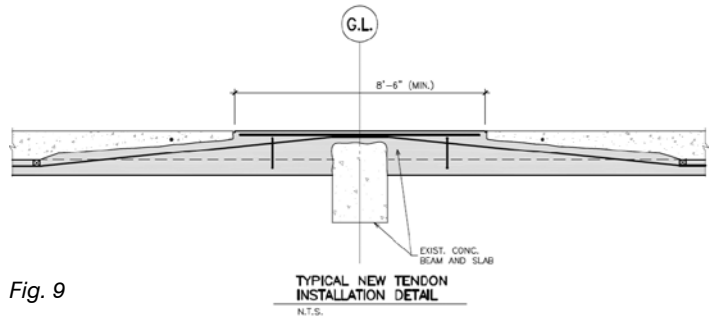

Fig. 9



Fig. 10



Fig. 11

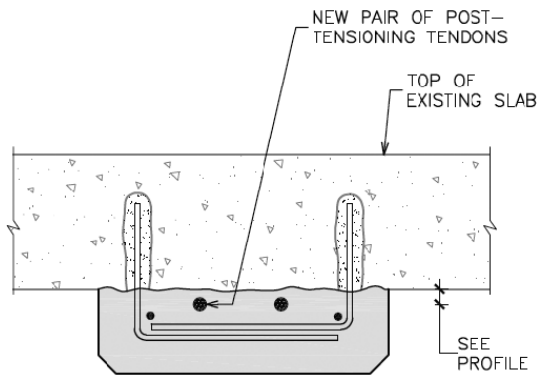

Fig. 12



Fig. 13



Fig. 14



Fig. 15

the garage during construction and minimized lost parking (refer to Fig. 14);

3. Minimized the need for shoring and reshoring as the existing post-tensioning system was maintained during construction until the new external system was ready to be engaged; and
4. Provided a solution that was approximately half the construction cost of the complete slab replacement option, which did not include the lost revenue component associated with complete replacement.

CONSTRUCTION COST AND SERVICE LIFE

The construction cost for this external post-tensioning solution was in the order of \$28 per square foot (\$300 per square meter) of suspended slab (Canadian dollars). The solution was designed so that the suspended slabs of this facility will remain in a serviceable condition, if properly maintained, for another 40 years. The maintenance will consist of continued repair and renewal of the waterproofing, as well as localized repair to corrosion-related deterioration as it develops.

REFERENCES

“Acceptance Standards for Post-Tensioning Systems,” Post-Tensioning Institute, Farmington Hills, MI, 1998, 53 pp.

ACI Committee 421, “Guide to Shear Reinforcement for Slabs (ACI 421.1R-08),” American Concrete Institute, Farmington Hills, MI, 2008, 15 pp.

ASTM A414/A414M, “Standard Specification for Steel, Sheet, Carbon, for Pressure Vessels,” ASTM International, West Conshohocken, PA, 2007, 4 pp.

Newman, A., 2001, “Structural Renovation of Buildings: Methods, Details, and Design Examples,” McGraw-Hill, USA, 688 pp.



Philip Sarvinis, PEng, is currently the Managing Principal of Read Jones Christoffersen’s Building Science and Restoration Group in Toronto, ON, Canada. He has 20 years of experience in the evaluation, rehabilitation, and protection of building structures and is currently licensed to practice engineering in Ontario, New Brunswick, Newfoundland, and Nova Scotia. Sarvinis is the President of the Building and Concrete Restoration Association of Ontario, and a member of the Canadian Parking Association, the International Concrete Repair Institute, the American Concrete Institute, the Canadian Society of Civil Engineers, the American Society of Civil Engineers, and Construction Specifications Canada. Sarvinis received an honors degree in engineering from the University of Toronto, Toronto, ON, Canada, in 1989.